

We reserve all rights in this document and in the information contained therein. Reproduction, use or disclosure to third parties without express authority is strictly forbidden. © Copyright 2003 ABB

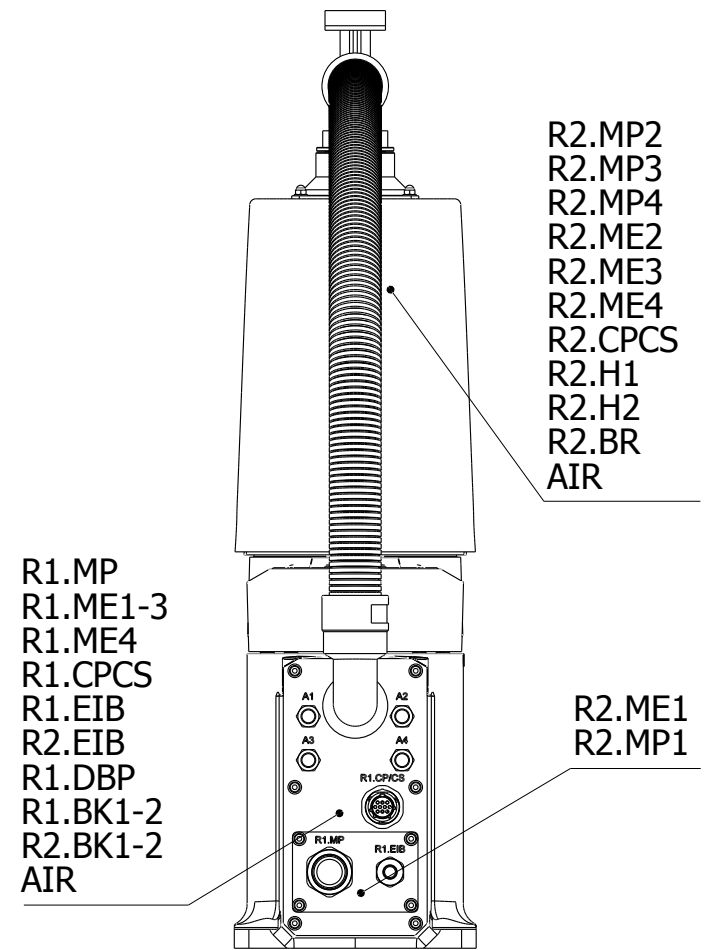

Latest revision:

Prepared by, date: Jing Wu | Approved by, date:

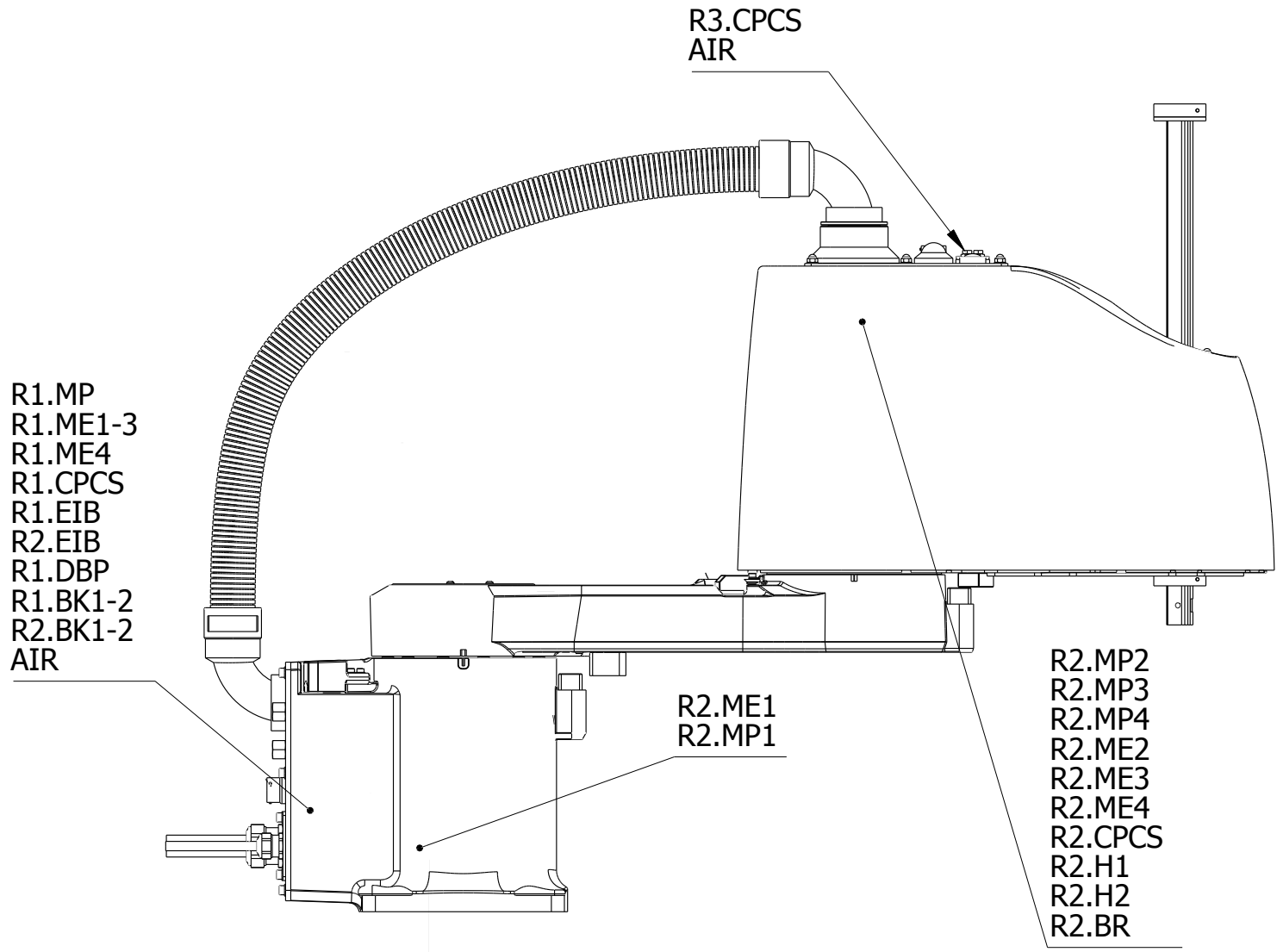

IRB910SC  
Conn Point Location

Approved  
Document no. 3HAC056159-002 00

Plant: =  
Location: +  
Sublocation: +

Rev. Ind Page 1  
Next 2  
Total 6

We reserve all rights in this document and in the information contained therein. Reproduction, use or disclosure to third parties without express authority is strictly forbidden. © Copyright 2003 ABB

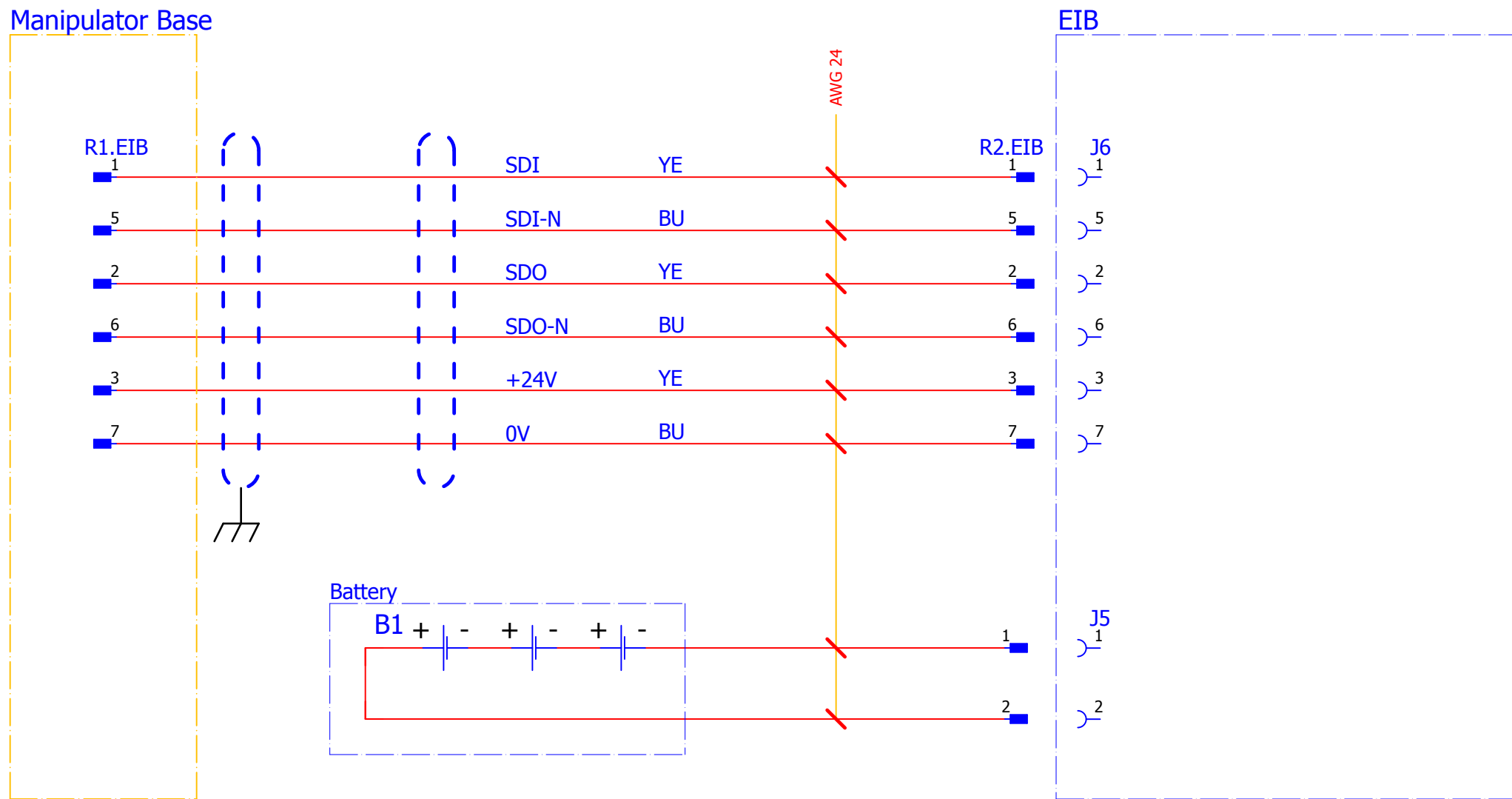

Latest revision:

Prepared by, date: Jing Wu | Approved by, date:



Lab/Office:  
CNAUS  
R&D-RM

IRB910SC  
EIB

Approved

Document no.

3HAC056159-002 00

Plant: =  
Location: +  
Sublocation: +

Rev. Ind Page 2  
Next 3  
Total 6

We reserve all rights in this document and in the information contained therein. Reproduction, use or disclosure to third parties without express authority is strictly forbidden. ? Copyright 2003 ABB

Manipulator Base

R1.CP/CS

- A
- B
- C
- D
- E
- F
- G
- H
- J
- K

- YE
- BU
- YE
- BU
- YE
- BU
- YE
- BU
- YE
- BU

AWG 24

R2.CPCS

- 1
- 2
- 3
- 4
- 5
- 6
- 7
- 8
- 9
- 10

- YE
- BU
- YE
- BU
- YE
- BU
- YE
- BU
- YE
- BU

AWG24

Manipulator Arm 2

R3.CP/CS

- A
- B
- C
- D
- E
- F
- G
- H
- J
- K

Latest revision:

Prepared by, date: Jing Wu      Approved by, date:



IRB910SC  
Customer Connection

Approved

Plant: =  
Location: +  
Sublocation: +

Document no.      Rev. Ind      Page 3  
3HAC056159-002 00      Next 4  
Total 6

We reserve all rights in this document and in the information contained therein. Reproduction, use or disclosure to third parties without express authority is strictly forbidden. © Copyright 2003 ABB

Manipulator Base

Motor1

Manipulator Base

Motor3

Motor2

Motor4

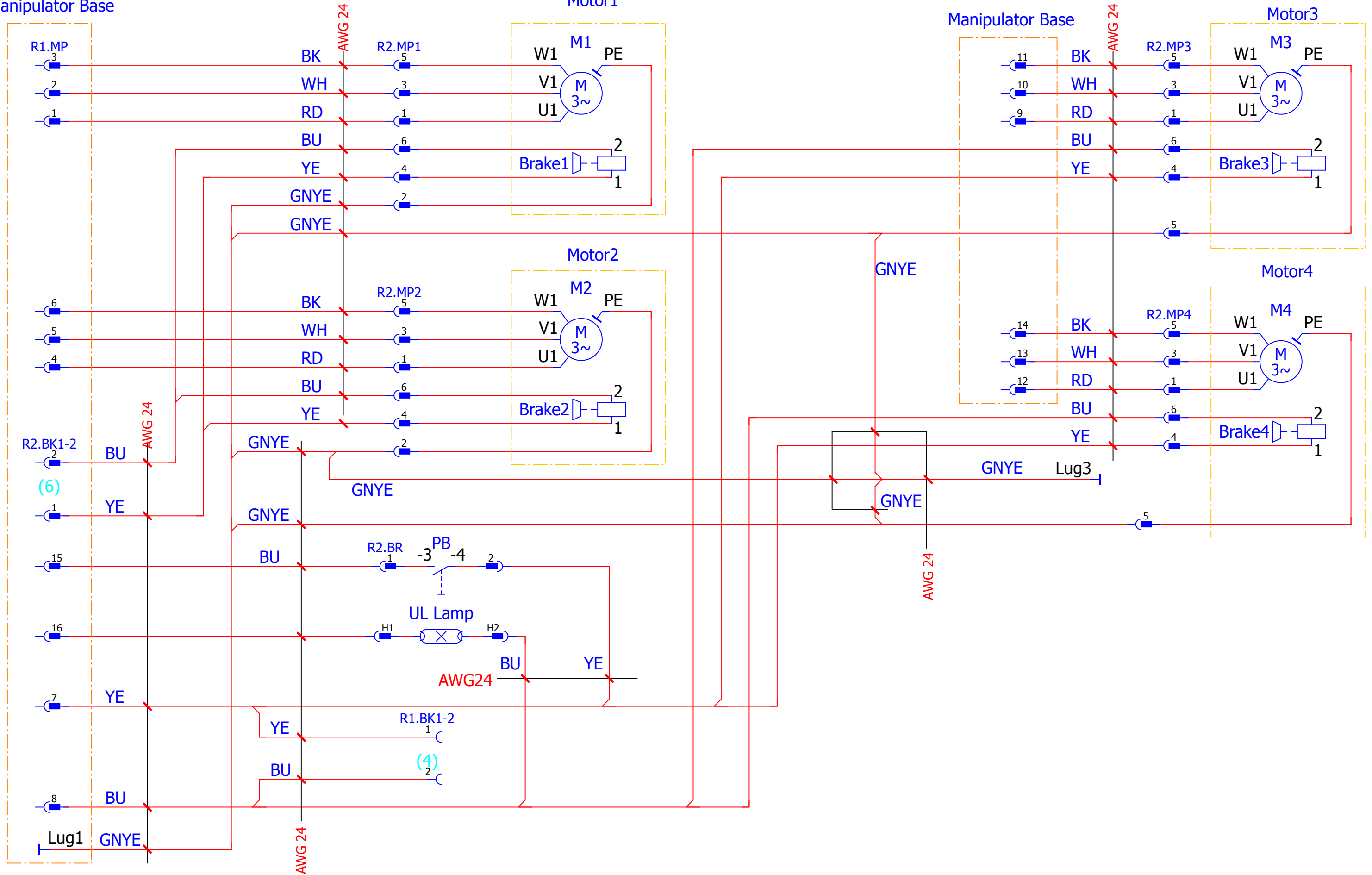

Latest revision:



Lab/Office:  
CNAUS  
R&D-RM

IRB910SC  
Cable Harness Main

Plant: =  
Location: +  
Sublocation: +

Approved

Document no. 3HAC056159-002 00 Rev. Ind Page 4  
Next 5  
Total 6

Prepared by, date: Jing Wu

Approved by, date:

We reserve all rights in this document and in the information contained therein. Reproduction, use or disclosure to third parties without express authority is strictly forbidden. © Copyright 2003 ABB

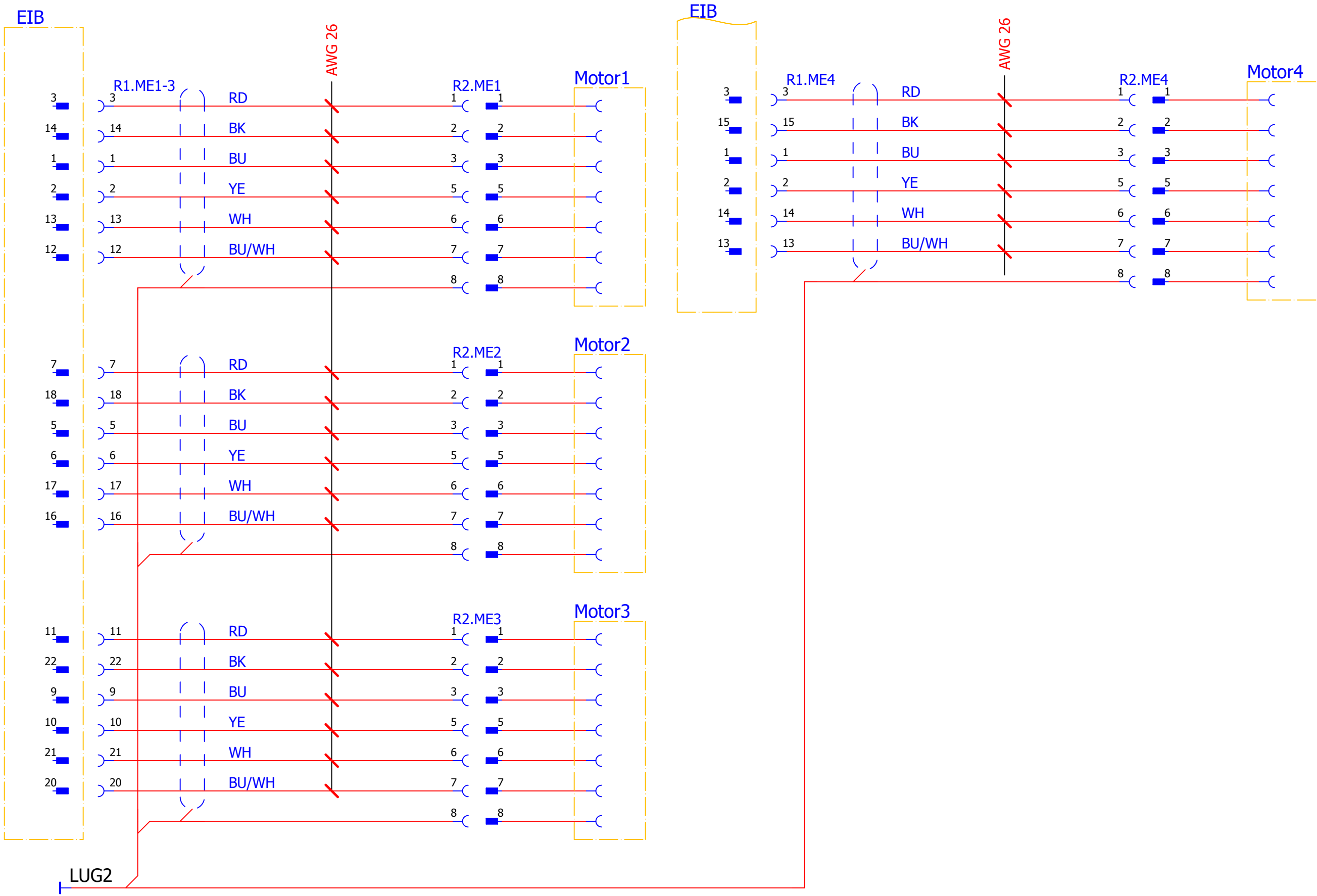

Latest revision:

Prepared by, date: Jing Wu      Approved by, date:

**ABB**  
CNAUS  
Lab/Office:  
CNAUS  
R&D-RM

**IRB910SC**  
Cable Harness EIB

Approved  
Document no. **3HAC056159-002 00**

Plant: =  
Location: +  
Sublocation: +

Rev. Ind Page 5  
Next 6  
Total 6

Manipulator base

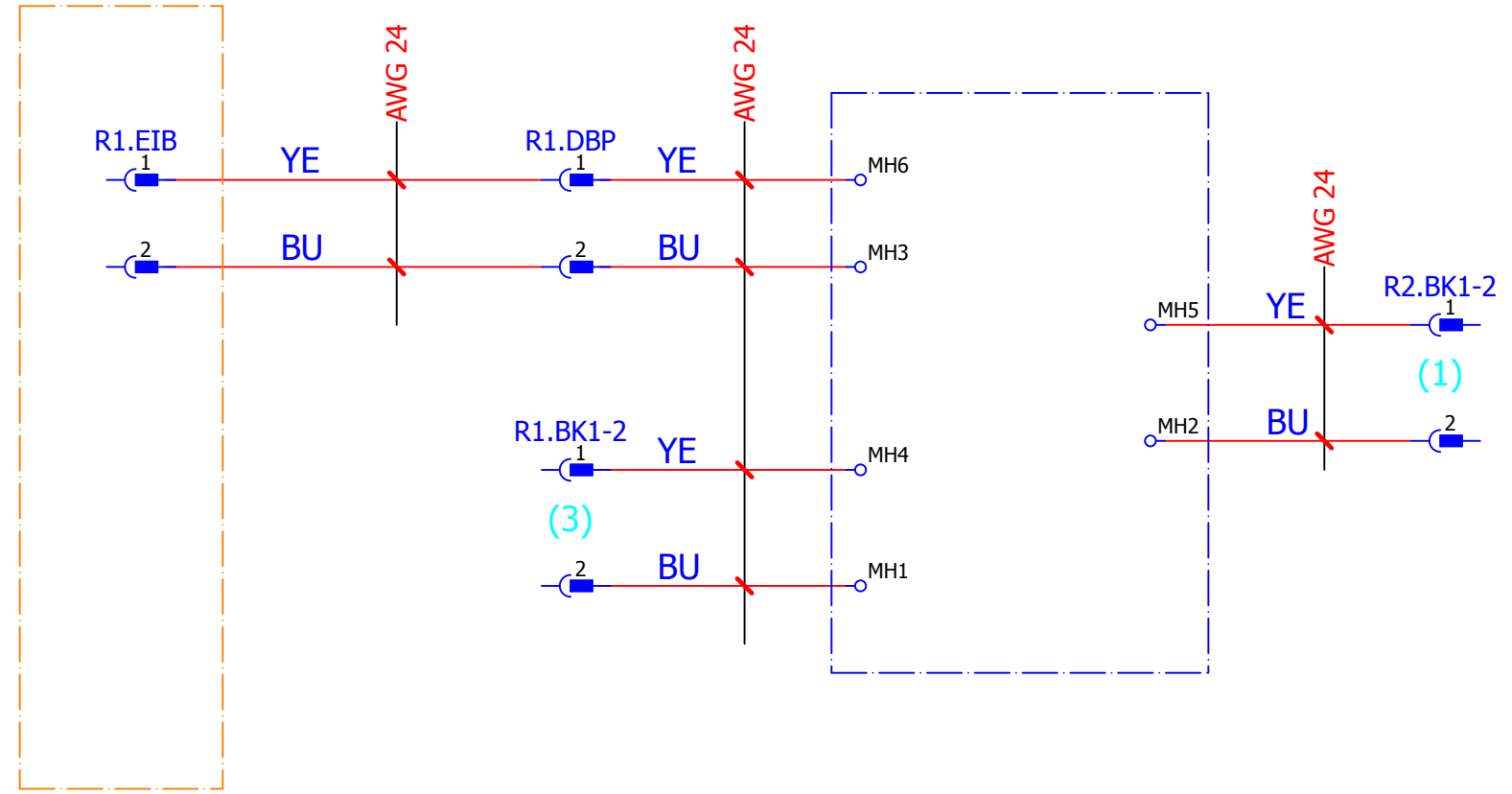

We reserve all rights in this document and in the information contained therein. Reproduction, use or disclosure to third parties without express authority is strictly forbidden. © Copyright 2003 ABB

Latest revision:

Prepared by, date: Jing Wu      Approved by, date:



IRB910SC  
Cable Harness delay board

Approved      Plant: =  
Location: +  
Sublocation: +

Document no.      Rev. Ind      Page 6  
3HAC056159-002 00      Next  
Total 6